

Line-No.	Date	27.02.2012	Order-No.		Amount		Supplier
	Path	aserpack/filesW	Author	Yashin A	Height		Laserpack Fryazino
	File	e> ECMA_B4150.d	Customer		Manufacturer		
	Holz 10/15/18		Line type		Material		
	Sonstiges		Pointage		Mat. Table		

Rule Processing System ACS 100 for ISO 9000

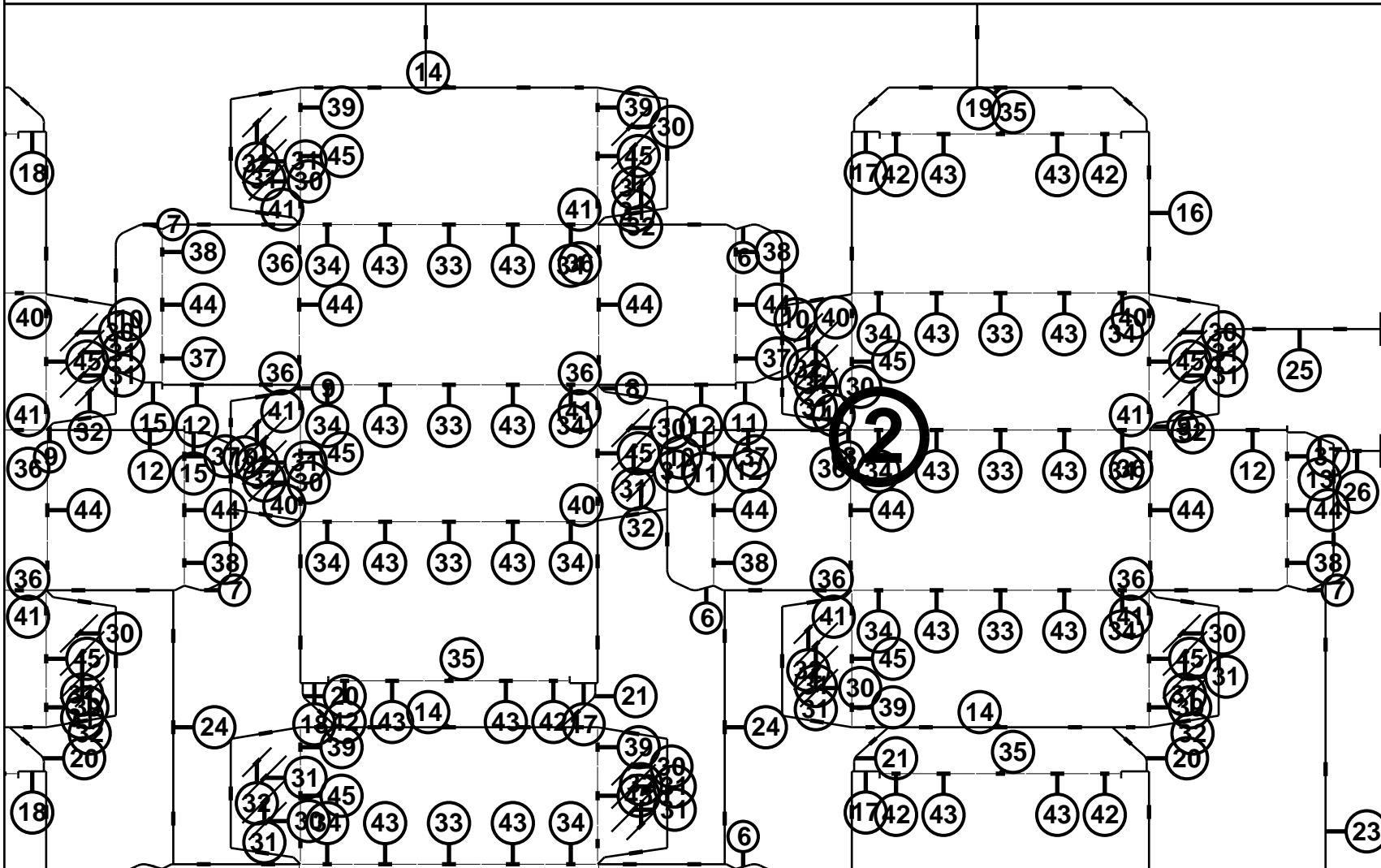

Line-No.	Date	27.02.2012	Order-No.		Amount		Supplier Laserpack Fryazino
	Path	aserpack/filesW	Author	Yashin A	Height		
	File	e> ECMA_B4150.cd	Customer		Manufacturer		
	Holz 10/15/18		Line type		Material		
	Sonstiges		Pointage		Mat. Table		

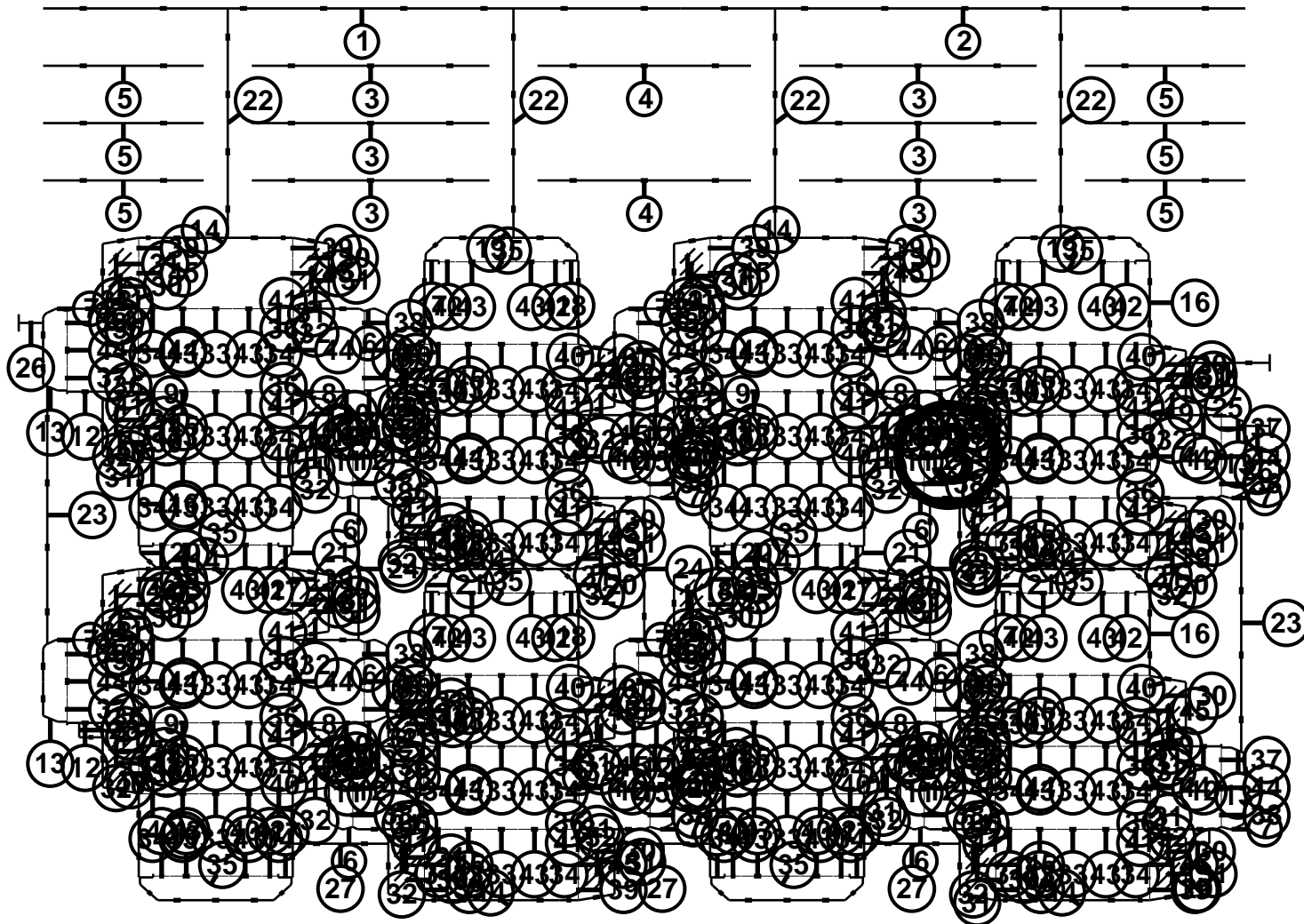

Line-No.	Date	27.02.2012	Order-No.		Amount		Supplier
	Path	aserpack/filesW	Author	Yashin A	Height		Laserpack Fryazino
	File	e> ECMA_B4150.d	Customer		Manufacturer		
	Holz 10/15/18		Line type		Material		
	Sonstiges		Pointage		Mat. Table		
						Die-Side	

Rule Processing System ACS 100 for ISO 9000

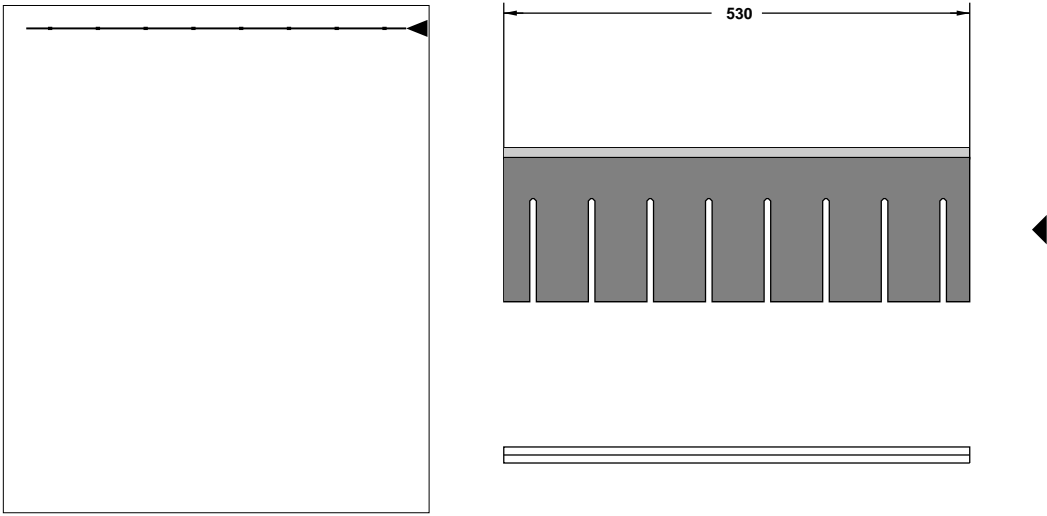

1	Line-No.	Date	27.02.2012	Order-No.		Amount	1	Supplier
	Path	aserpack/filesW	Author	Yashin A	Height	23.80	Laserpack Fryazino	
	File	e> ECMA_B4150.doc	Customer		Manufacturer	Boehler		
	Holz 10/15/18		Line type	Cut	Material	UNIVERSAL-T30		
	Sonstiges		Pointage	2.00	Mat. Table	04	Die-Side	

Rule Processing System ACS 100 for ISO 9000

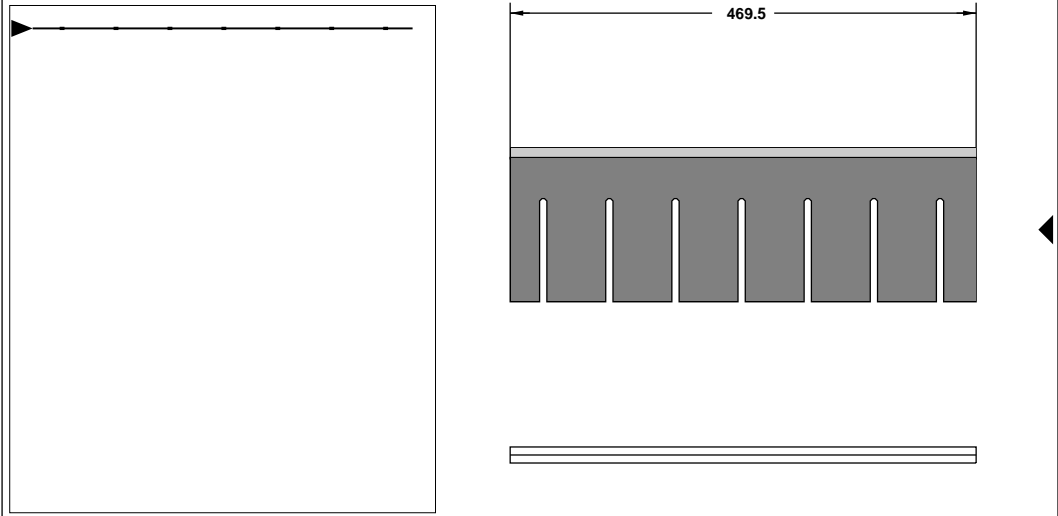

2	Line-No.	Date	27.02.2012	Order-No.		Amount	1	Supplier
	Path	aserpack/filesW	Author	Yashin A	Height	23.80	Laserpack Fryazino	
	File	e> ECMA_B4150.doc	Customer		Manufacturer	Boehler		
	Holz 10/15/18		Line type	Cut	Material	UNIVERSAL-T30		
	Sonstiges		Pointage	2.00	Mat. Table	04	Die-Side	

Rule Processing System ACS 100 for ISO 9000

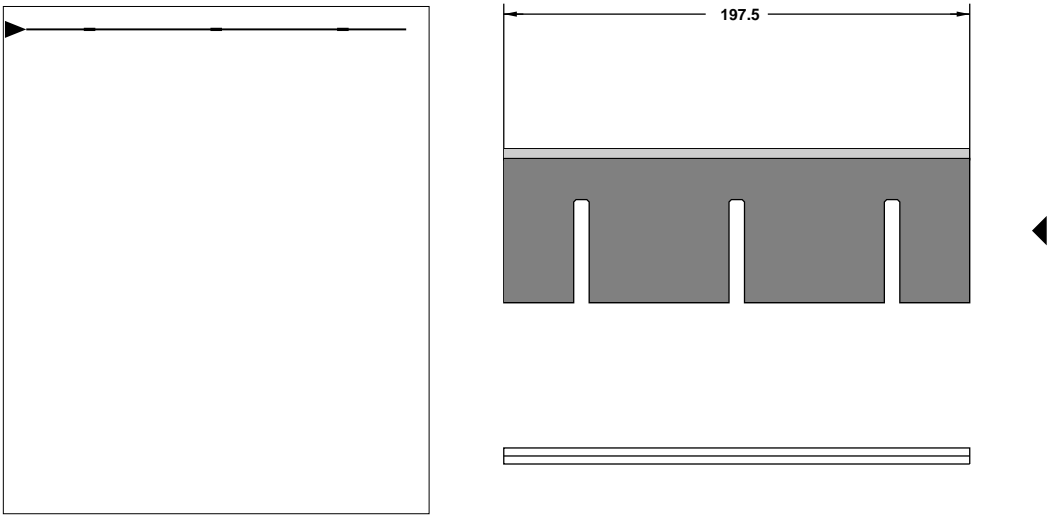

3	Line-No.	Date	27.02.2012	Order-No.		Amount	6	Supplier
	Path	aserpack/filesW	Author	Yashin A	Height	23.80	Laserpack Fryazino	
	File	e> ECMA_B4150.doc	Customer		Manufacturer	Boehler		
	Holz 10/15/18		Line type	Cut	Material	UNIVERSAL-T30		
	Sonstiges		Pointage	2.00	Mat. Table	04	Die-Side	

Rule Processing System ACS 100 for ISO 9000

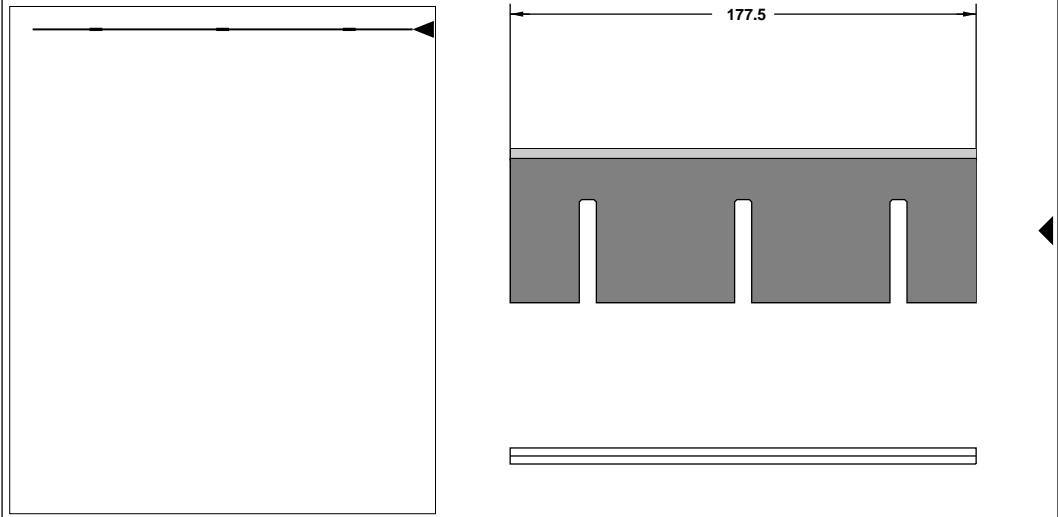

4	Line-No.	Date	27.02.2012	Order-No.		Amount	2	Supplier
	Path	aserpack/filesW	Author	Yashin A	Height	23.80	Laserpack Fryazino	
	File	e> ECMA_B4150.doc	Customer		Manufacturer	Boehler		
	Holz 10/15/18		Line type	Cut	Material	UNIVERSAL-T30		
	Sonstiges		Pointage	2.00	Mat. Table	04	Die-Side	

Rule Processing System ACS 100 for ISO 9000

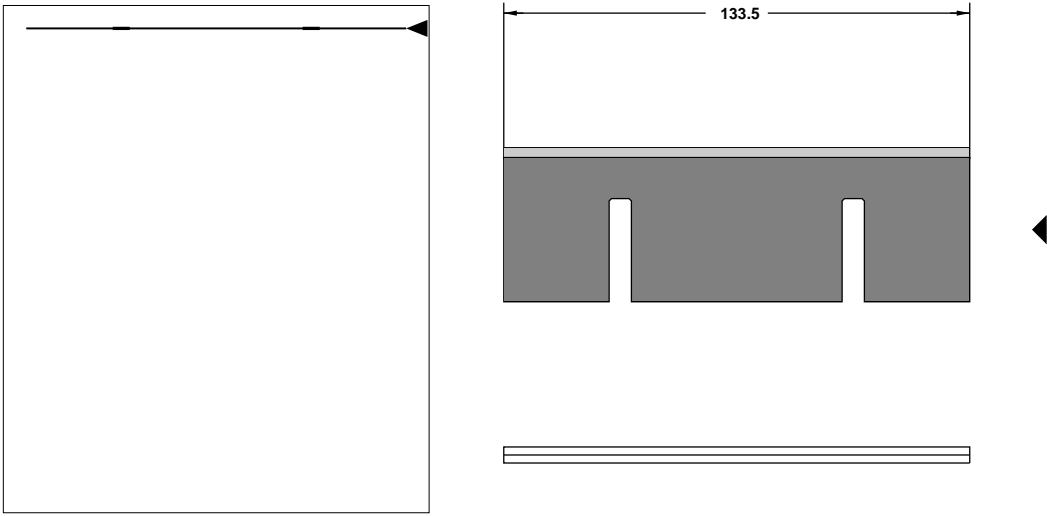

Line-No.	Date	27.02.2012	Order-No.		Amount	6	Supplier	
5	Path	aserpack/filesW	Author	Yashin A	Height	23.80	Laserpack Fryazino	
	File	e> ECMA_B4150.d	Customer		Manufacturer	Boehler		
	Holz 10/15/18		Line type	Cut	Material	UNIVERSAL-T30		
	Sonstiges		Pointage	2.00	Mat. Table	04		Die-Side

Rule Processing System ACS 100 for ISO 9000

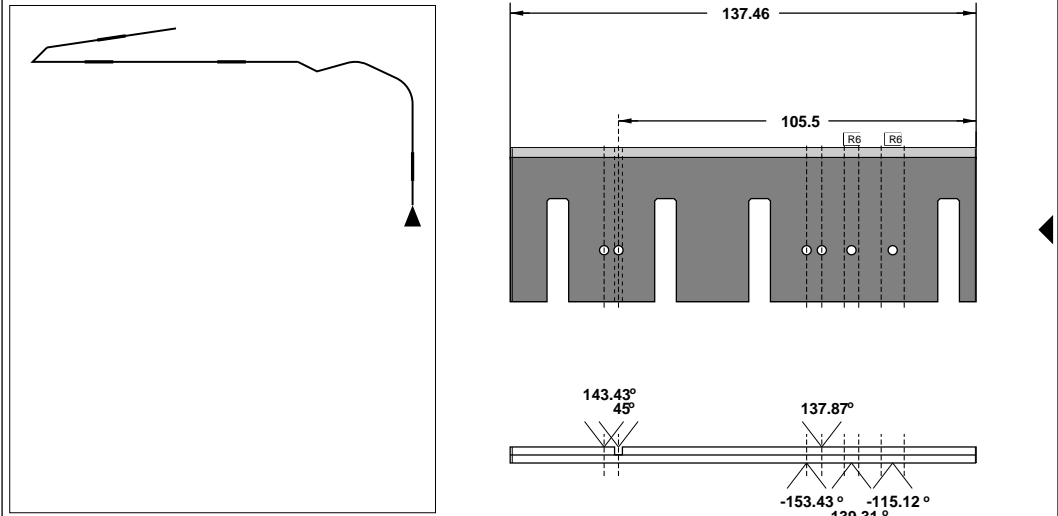

Line-No.	Date	27.02.2012	Order-No.		Amount	8	Supplier	
6	Path	aserpack/filesW	Author	Yashin A	Height	23.80	Laserpack Fryazino	
	File	e> ECMA_B4150.d	Customer		Manufacturer	Boehler		
	Holz 10/15/18		Line type	Cut	Material	UNIVERSAL-T30		
	Sonstiges		Pointage	2.00	Mat. Table	04		Die-Side

Rule Processing System ACS 100 for ISO 9000

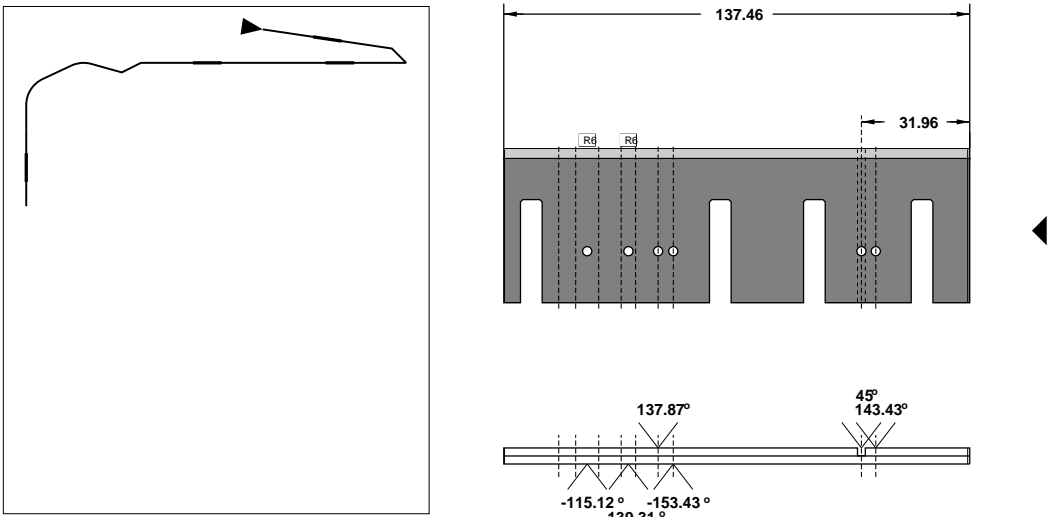

Line-No.	Date	27.02.2012	Order-No.		Amount	8	Supplier	
7	Path	aserpack/filesW	Author	Yashin A	Height	23.80	Laserpack Fryazino	
	File	e> ECMA_B4150.d	Customer		Manufacturer	Boehler		
	Holz 10/15/18		Line type	Cut	Material	UNIVERSAL-T30		
	Sonstiges		Pointage	2.00	Mat. Table	04		Die-Side

Rule Processing System ACS 100 for ISO 9000

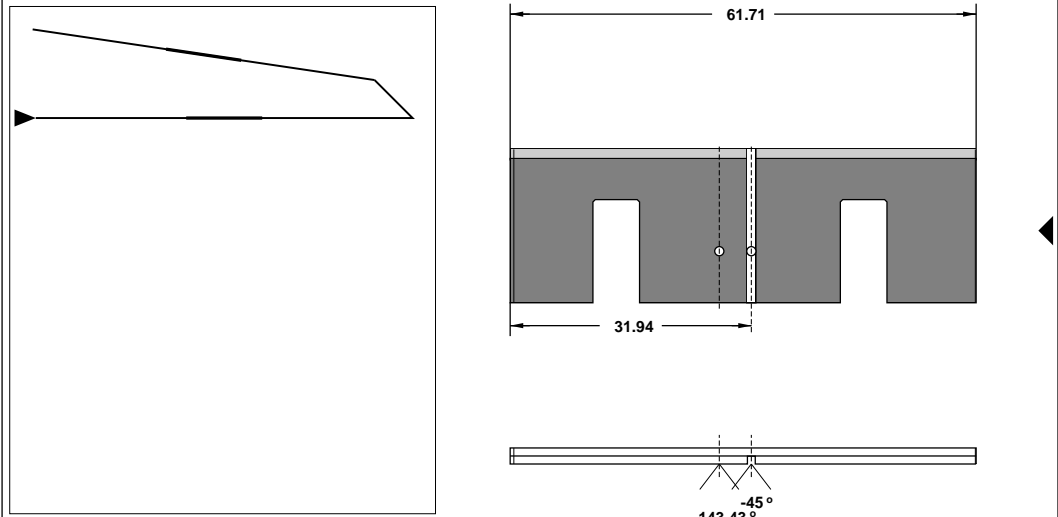

Line-No.	Date	27.02.2012	Order-No.		Amount	8	Supplier	
8	Path	aserpack/filesW	Author	Yashin A	Height	23.80	Laserpack Fryazino	
	File	e> ECMA_B4150.d	Customer		Manufacturer	Boehler		
	Holz 10/15/18		Line type	Cut	Material	UNIVERSAL-T30		
	Sonstiges		Pointage	2.00	Mat. Table	04		Die-Side

Rule Processing System ACS 100 for ISO 9000

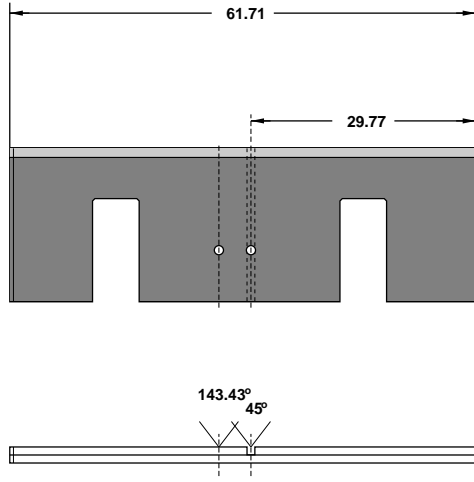
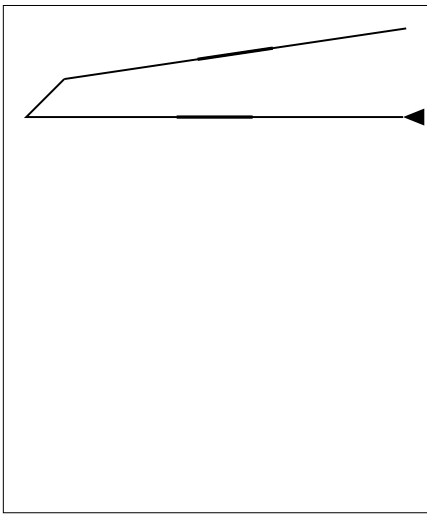

9	Line-No.	Date	27.02.2012	Order-No.		Amount	8	Supplier
	Path	aserpack/filesW	Author	Yashin A	Height	23.80	Laserpack Fryazino	
	File	e> ECMA_B4150.d	Customer		Manufacturer	Boehler		
	Holz 10/15/18		Line type	Cut	Material	UNIVERSAL-T30		
	Sonstiges		Pointage	2.00	Mat. Table	04	Die-Side	

Rule Processing System ACS 100 for ISO 9000

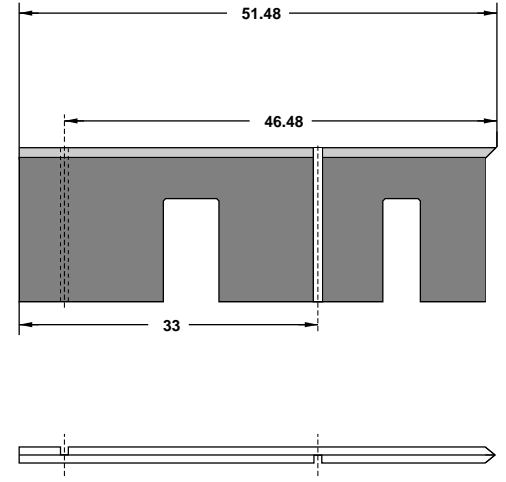

10	Line-No.	Date	27.02.2012	Order-No.		Amount	12	Supplier
	Path	aserpack/filesW	Author	Yashin A	Height	23.80	Laserpack Fryazino	
	File	e> ECMA_B4150.d	Customer		Manufacturer	Boehler		
	Holz 10/15/18		Line type	Cut	Material	UNIVERSAL-T30		
	Sonstiges		Pointage	2.00	Mat. Table	04	Die-Side	

Rule Processing System ACS 100 for ISO 9000

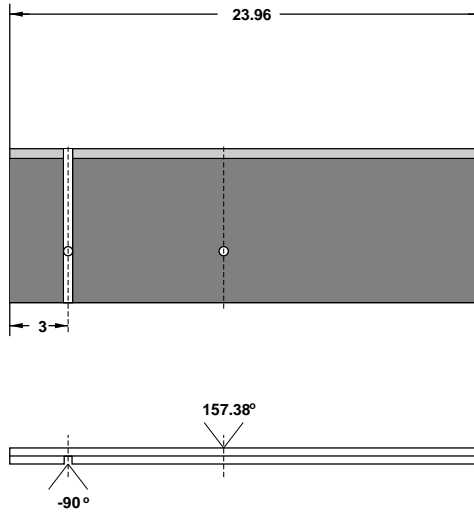
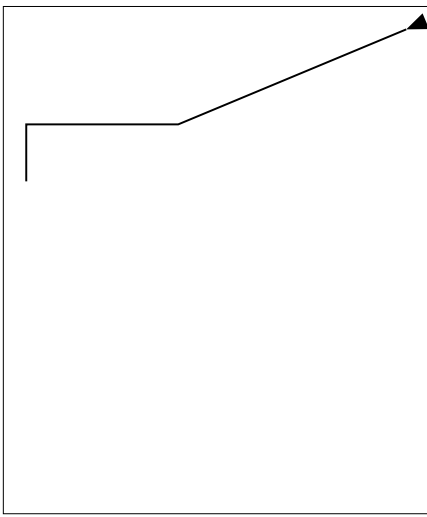

11	Line-No.	Date	27.02.2012	Order-No.		Amount	8	Supplier
	Path	aserpack/filesW	Author	Yashin A	Height	23.80	Laserpack Fryazino	
	File	e> ECMA_B4150.d	Customer		Manufacturer	Boehler		
	Holz 10/15/18		Line type	Cut	Material	UNIVERSAL-T30		
	Sonstiges		Pointage	2.00	Mat. Table	04	Die-Side	

Rule Processing System ACS 100 for ISO 9000

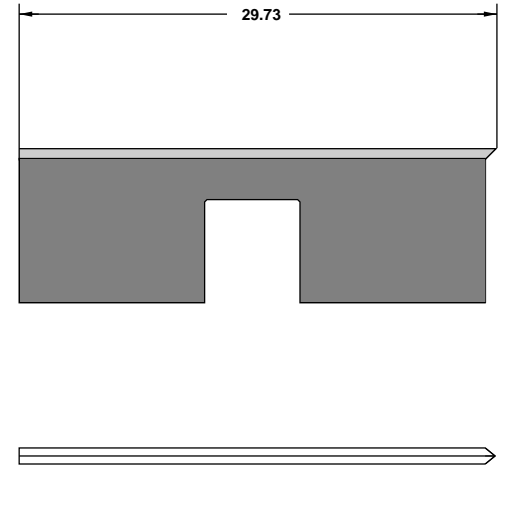
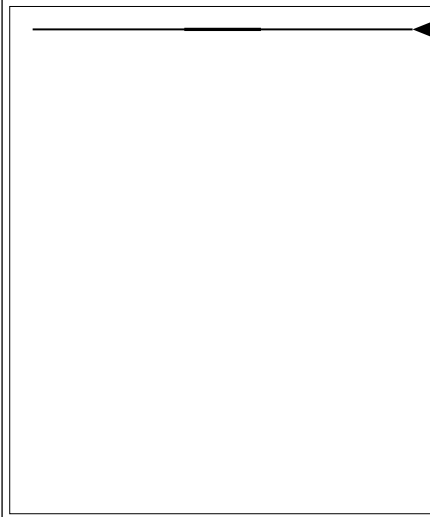

12	Line-No.	Date	27.02.2012	Order-No.		Amount	16	Supplier
	Path	aserpack/filesW	Author	Yashin A	Height	23.80	Laserpack Fryazino	
	File	e> ECMA_B4150.d	Customer		Manufacturer	Boehler		
	Holz 10/15/18		Line type	Cut	Material	UNIVERSAL-T30		
	Sonstiges		Pointage	2.00	Mat. Table	04	Die-Side	

Rule Processing System ACS 100 for ISO 9000

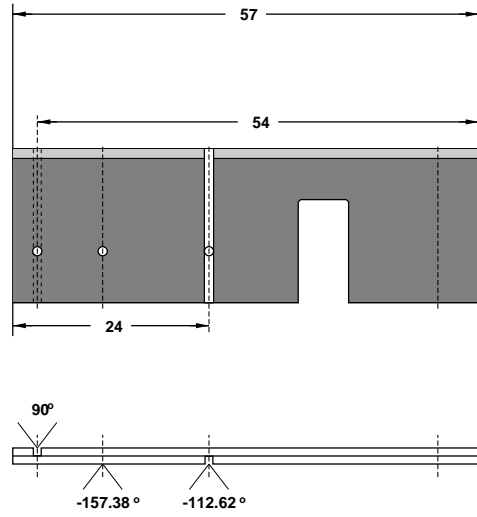
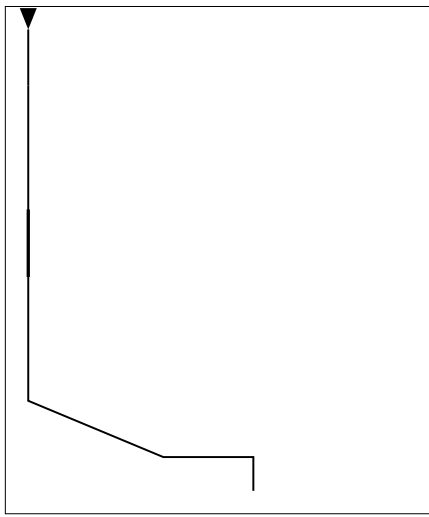

13	Line-No.	Date	27.02.2012	Order-No.		Amount	4	Supplier
	Path	aserpack/filesW	Author	Yashin A	Height	23.80	Laserpack Fryazino	
	File	e> ECMA_B4150.d	Customer		Manufacturer	Boehler		
	Holz 10/15/18		Line type	Cut	Material	UNIVERSAL-T30		
	Sonstiges		Pointage	2.00	Mat. Table	04	Die-Side	

Rule Processing System ACS 100 for ISO 9000

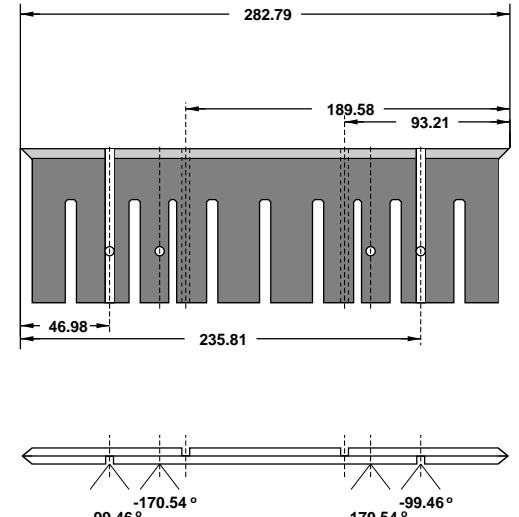
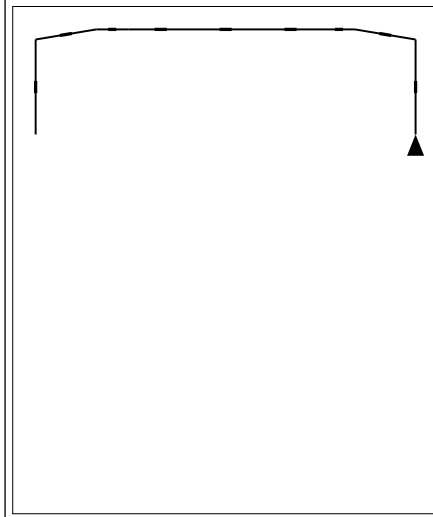

14	Line-No.	Date	27.02.2012	Order-No.		Amount	8	Supplier
	Path	aserpack/filesW	Author	Yashin A	Height	23.80	Laserpack Fryazino	
	File	e> ECMA_B4150.d	Customer		Manufacturer	Boehler		
	Holz 10/15/18		Line type	Cut	Material	UNIVERSAL-T30		
	Sonstiges		Pointage	2.00	Mat. Table	04	Die-Side	

Rule Processing System ACS 100 for ISO 9000

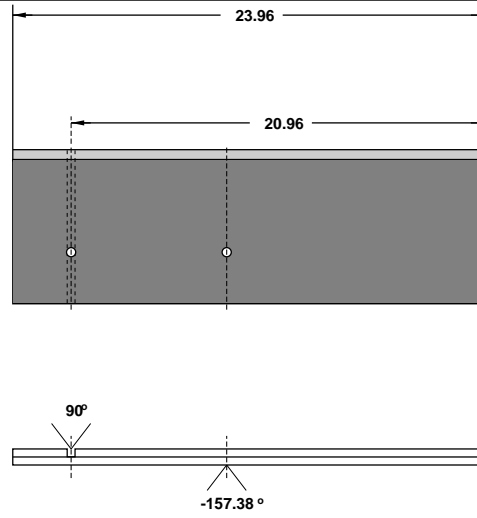
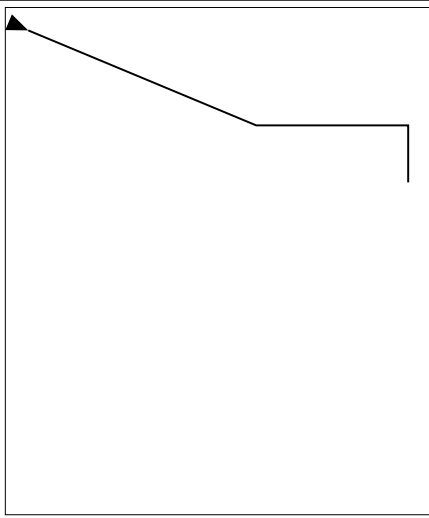

15	Line-No.	Date	27.02.2012	Order-No.		Amount	4	Supplier
	Path	aserpack/filesW	Author	Yashin A	Height	23.80	Laserpack Fryazino	
	File	e> ECMA_B4150.d	Customer		Manufacturer	Boehler		
	Holz 10/15/18		Line type	Cut	Material	UNIVERSAL-T30		
	Sonstiges		Pointage	2.00	Mat. Table	04	Die-Side	

Rule Processing System ACS 100 for ISO 9000

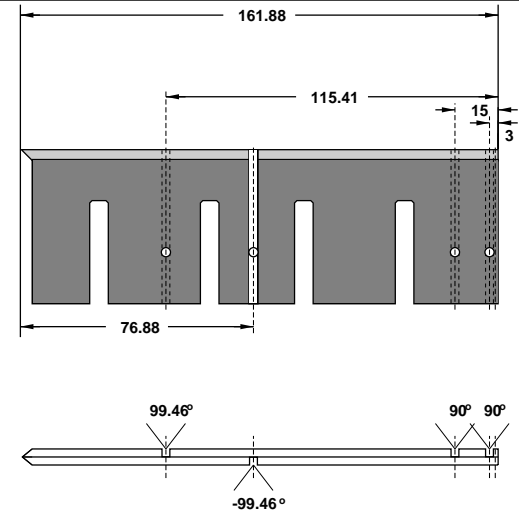
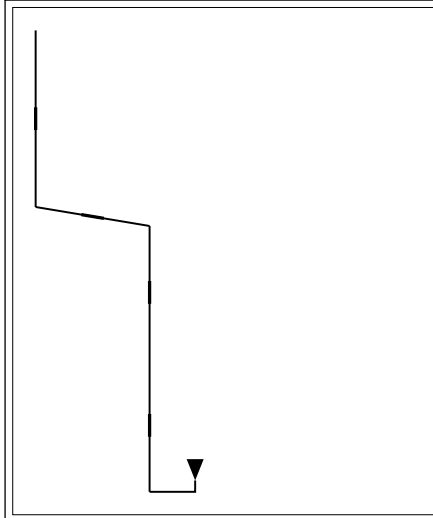

16	Line-No.	Date	27.02.2012	Order-No.		Amount	4	Supplier
	Path	aserpack/filesW	Author	Yashin A	Height	23.80	Laserpack Fryazino	
	File	e> ECMA_B4150.d	Customer		Manufacturer	Boehler		
	Holz 10/15/18		Line type	PERFO	Material	UNIVERSAL-T30		
	Sonstiges		Pointage	2.00	Mat. Table	04	Die-Side	

Rule Processing System ACS 100 for ISO 9000

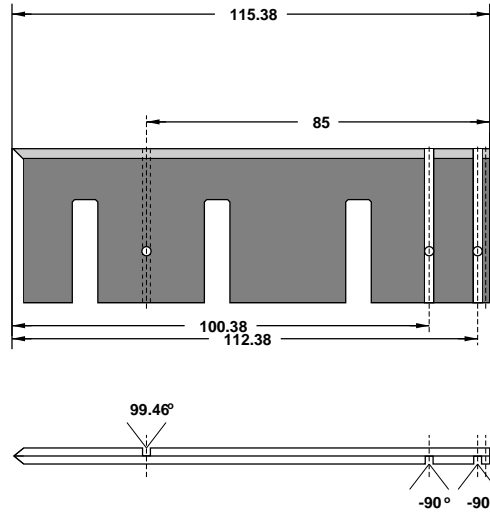
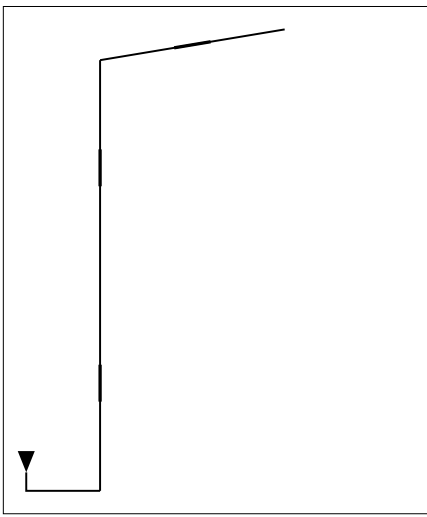

Line-No.	Date	27.02.2012	Order-No.		Amount	8	Supplier
17	Path	aserpack/filesW	Author	Yashin A	Height	23.80	Laserpack Fryazino
	File	e> ECMA_B4150.d	Customer		Manufacturer	Boehler	
	Holz 10/15/18		Line type	PERFO	Material	UNIVERSAL-T30	
	Sonstiges		Pointage	2.00	Mat. Table	04	
					Die-Side		

Rule Processing System ACS 100 for ISO 9000

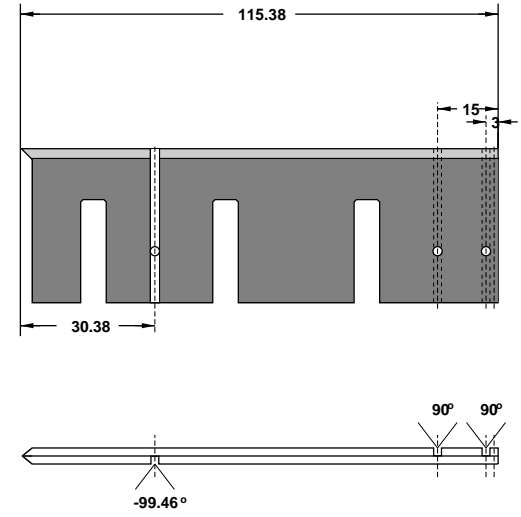
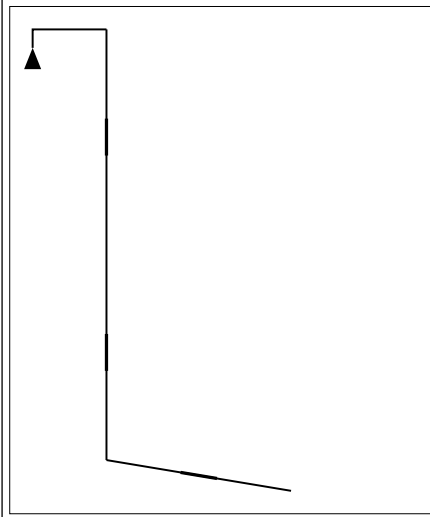

Line-No.	Date	27.02.2012	Order-No.		Amount	4	Supplier
18	Path	aserpack/filesW	Author	Yashin A	Height	23.80	Laserpack Fryazino
	File	e> ECMA_B4150.d	Customer		Manufacturer	Boehler	
	Holz 10/15/18		Line type	PERFO	Material	UNIVERSAL-T30	
	Sonstiges		Pointage	2.00	Mat. Table	04	
					Die-Side		

Rule Processing System ACS 100 for ISO 9000

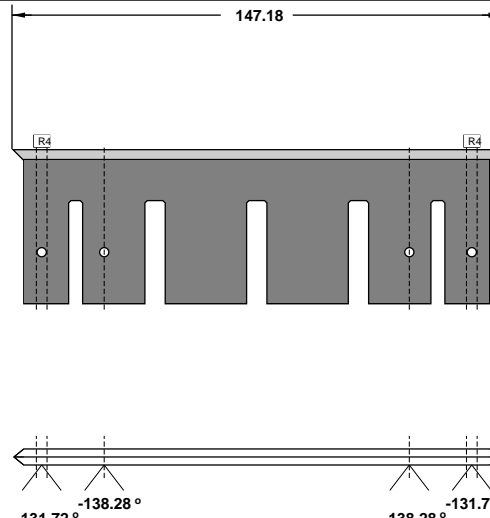
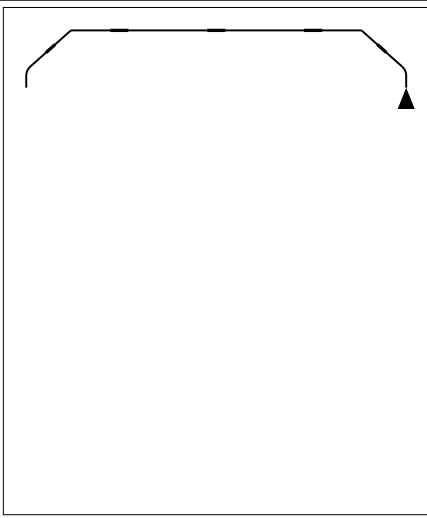

Line-No.	Date	27.02.2012	Order-No.		Amount	4	Supplier
19	Path	aserpack/filesW	Author	Yashin A	Height	23.80	Laserpack Fryazino
	File	e> ECMA_B4150.d	Customer		Manufacturer	Boehler	
	Holz 10/15/18		Line type	Cut	Material	UNIVERSAL-T30	
	Sonstiges		Pointage	2.00	Mat. Table	04	
					Die-Side		

Rule Processing System ACS 100 for ISO 9000

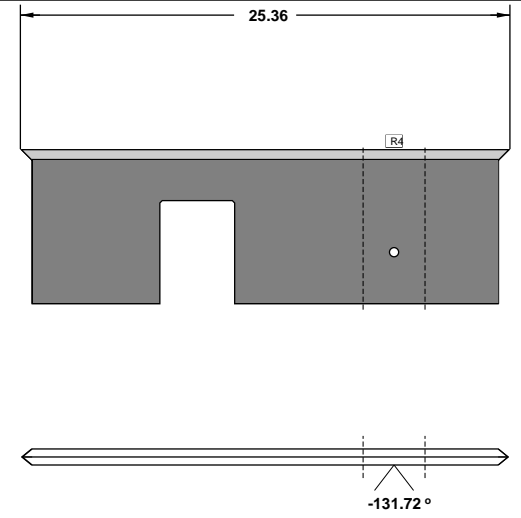
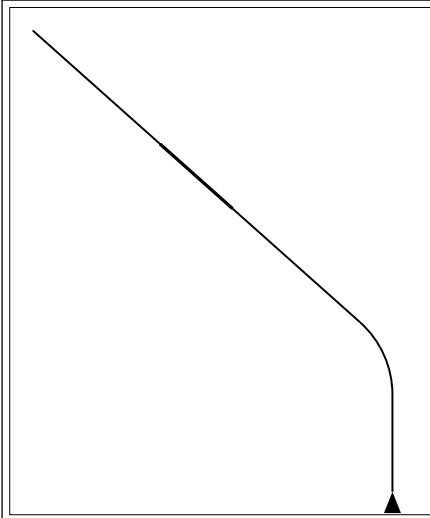

Line-No.	Date	27.02.2012	Order-No.		Amount	4	Supplier
20	Path	aserpack/filesW	Author	Yashin A	Height	23.80	Laserpack Fryazino
	File	e> ECMA_B4150.d	Customer		Manufacturer	Boehler	
	Holz 10/15/18		Line type	Cut	Material	UNIVERSAL-T30	
	Sonstiges		Pointage	2.00	Mat. Table	04	
					Die-Side		

Rule Processing System ACS 100 for ISO 9000

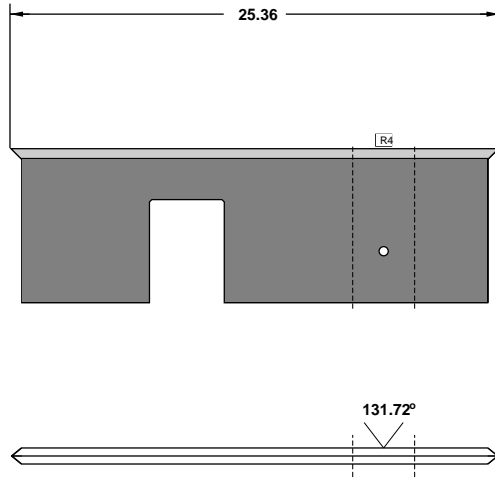
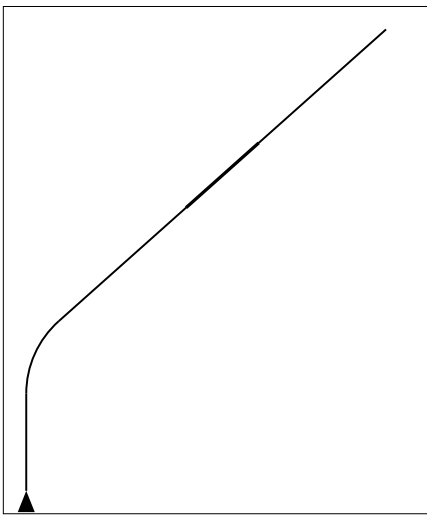

21	Line-No.	Date	27.02.2012	Order-No.		Amount	4	Supplier
	Path	aserpack/filesW	Author	Yashin A	Height	23.80	Laserpack Fryazino	
	File	e> ECMA_B4150.d	Customer		Manufacturer	Boehler		
	Holz 10/15/18		Line type	Cut	Material	UNIVERSAL-T30		
	Sonstiges		Pointage	2.00	Mat. Table	04	Die-Side	

Rule Processing System ACS 100 for ISO 9000

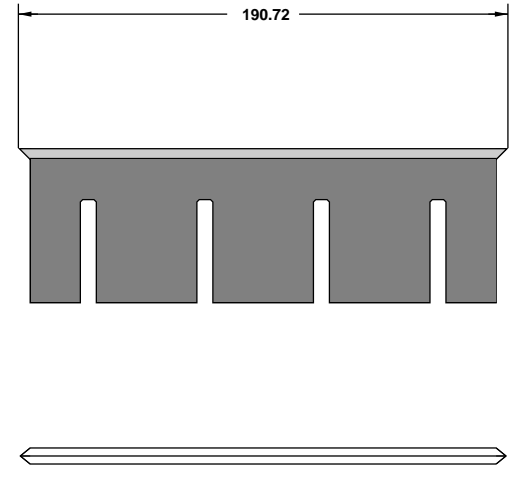

22	Line-No.	Date	27.02.2012	Order-No.		Amount	4	Supplier
	Path	aserpack/filesW	Author	Yashin A	Height	23.80	Laserpack Fryazino	
	File	e> ECMA_B4150.d	Customer		Manufacturer	Boehler		
	Holz 10/15/18		Line type	Cut	Material	UNIVERSAL-T30		
	Sonstiges		Pointage	2.00	Mat. Table	04	Die-Side	

Rule Processing System ACS 100 for ISO 9000

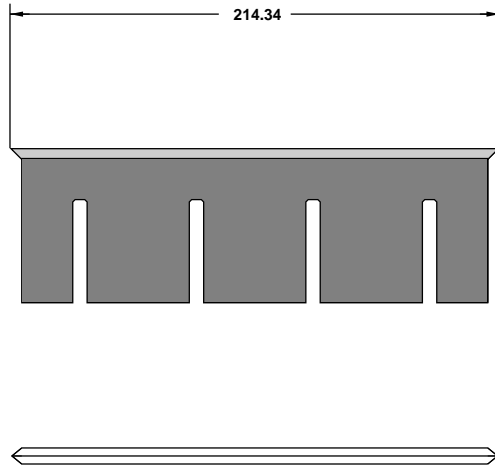
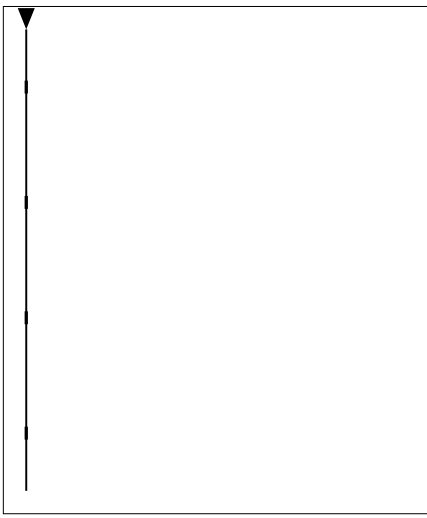

23	Line-No.	Date	27.02.2012	Order-No.		Amount	2	Supplier
	Path	aserpack/filesW	Author	Yashin A	Height	23.80	Laserpack Fryazino	
	File	e> ECMA_B4150.d	Customer		Manufacturer	Boehler		
	Holz 10/15/18		Line type	Cut	Material	UNIVERSAL-T30		
	Sonstiges		Pointage	2.00	Mat. Table	04	Die-Side	

Rule Processing System ACS 100 for ISO 9000

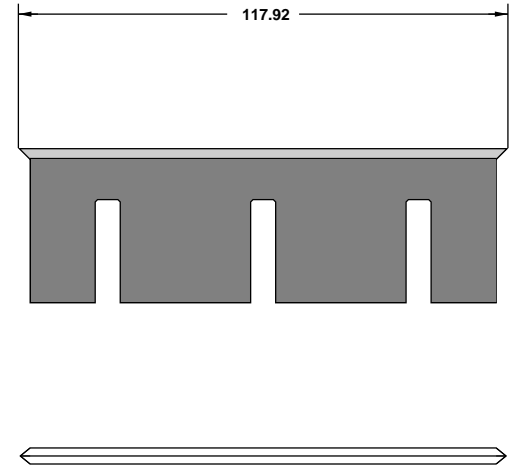

24	Line-No.	Date	27.02.2012	Order-No.		Amount	3	Supplier
	Path	aserpack/filesW	Author	Yashin A	Height	23.80	Laserpack Fryazino	
	File	e> ECMA_B4150.d	Customer		Manufacturer	Boehler		
	Holz 10/15/18		Line type	Cut	Material	UNIVERSAL-T30		
	Sonstiges		Pointage	2.00	Mat. Table	04	Die-Side	

Rule Processing System ACS 100 for ISO 9000

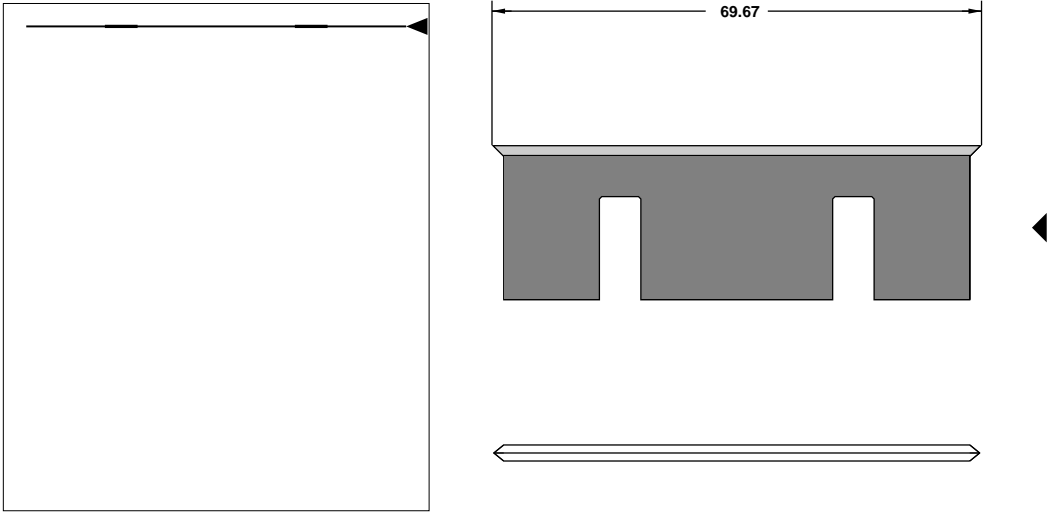

25	Line-No.		Date	27.02.2012	Order-No.		Amount	1	Supplier	
	Path	aserpack/filesW	Author	Yashin A	Height	23.80	Laserpack Fryazino			
	File	e> ECMA_B4150.doc	Customer		Manufacturer	Boehler				
	Holz 10/15/18		Line type	Cut	Material	UNIVERSAL-T30				
	Sonstiges		Pointage	2.00	Mat. Table	04	Die-Side			

Rule Processing System ACS 100 for ISO 9000

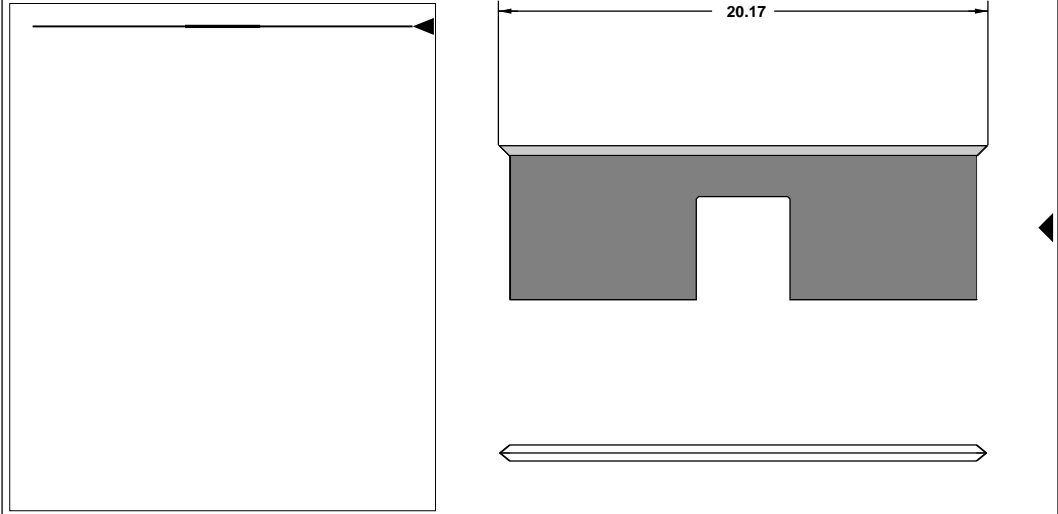

26	Line-No.		Date	27.02.2012	Order-No.		Amount	2	Supplier	
	Path	aserpack/filesW	Author	Yashin A	Height	23.80	Laserpack Fryazino			
	File	e> ECMA_B4150.doc	Customer		Manufacturer	Boehler				
	Holz 10/15/18		Line type	Cut	Material	UNIVERSAL-T30				
	Sonstiges		Pointage	2.00	Mat. Table	04	Die-Side			

Rule Processing System ACS 100 for ISO 9000

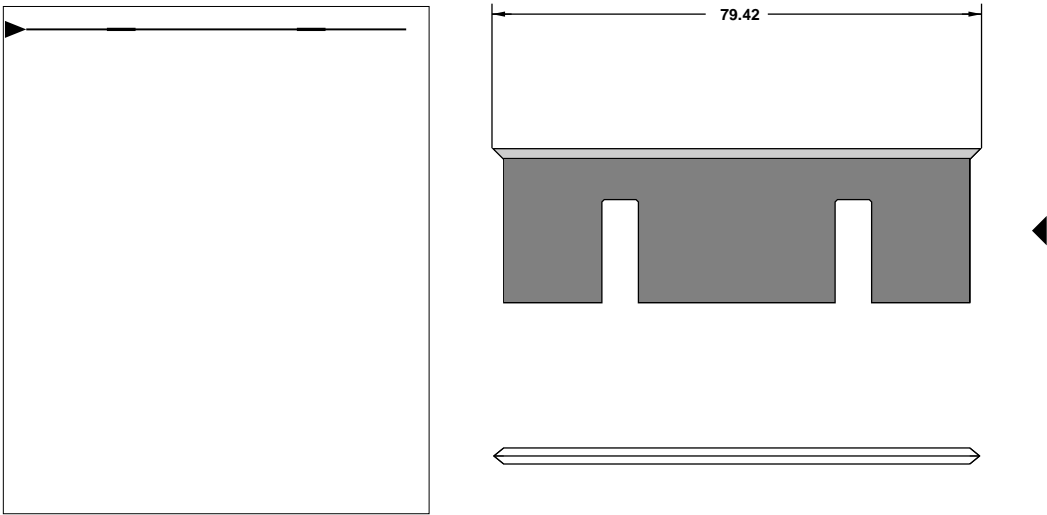

27	Line-No.		Date	27.02.2012	Order-No.		Amount	3	Supplier	
	Path	aserpack/filesW	Author	Yashin A	Height	23.80	Laserpack Fryazino			
	File	e> ECMA_B4150.doc	Customer		Manufacturer	Boehler				
	Holz 10/15/18		Line type	Cut	Material	UNIVERSAL-T30				
	Sonstiges		Pointage	2.00	Mat. Table	04	Die-Side			

Rule Processing System ACS 100 for ISO 9000

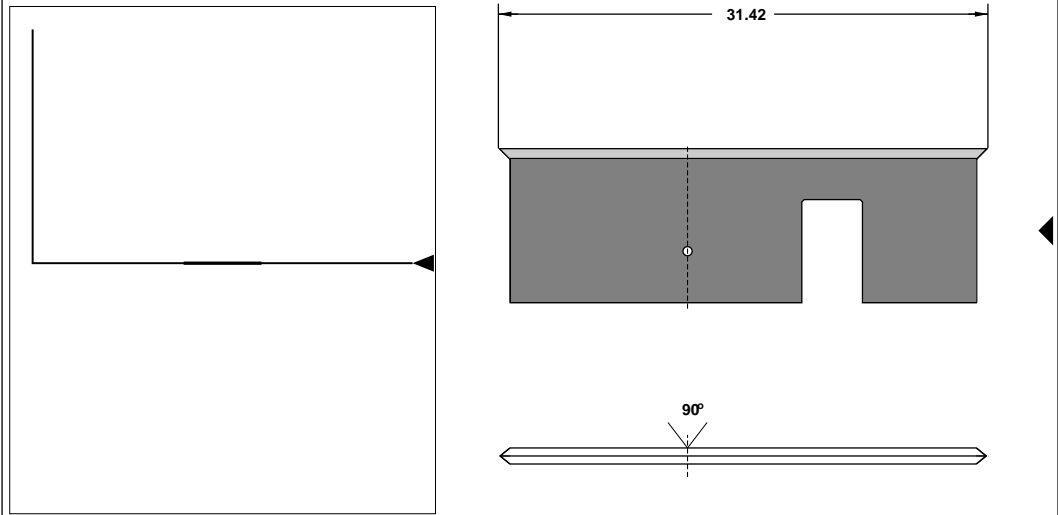

28	Line-No.		Date	27.02.2012	Order-No.		Amount	1	Supplier	
	Path	aserpack/filesW	Author	Yashin A	Height	23.80	Laserpack Fryazino			
	File	e> ECMA_B4150.doc	Customer		Manufacturer	Boehler				
	Holz 10/15/18		Line type	Cut	Material	UNIVERSAL-T30				
	Sonstiges		Pointage	2.00	Mat. Table	04	Die-Side			

Rule Processing System ACS 100 for ISO 9000

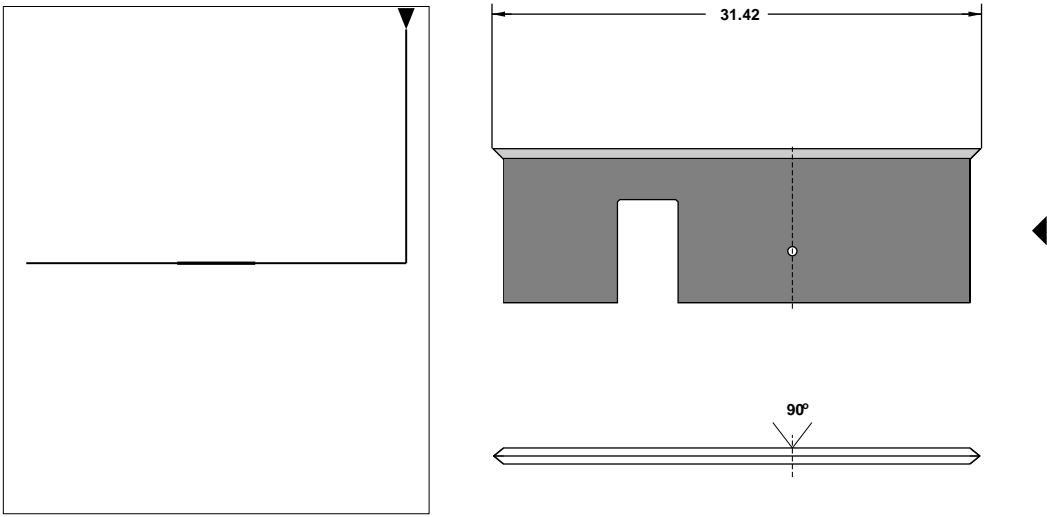

29	Line-No.		Date	27.02.2012	Order-No.		Amount	1	Supplier	
	Path	aserpack/filesW	Author	Yashin A	Height	23.80	Laserpack Fryazino			
	File	e> ECMA_B4150.d	Customer		Manufacturer	Boehler				
	Holz 10/15/18		Line type	Cut	Material	UNIVERSAL-T30				
	Sonstiges		Pointage	2.00	Mat. Table	04	Die-Side			

Rule Processing System ACS 100 for ISO 9000

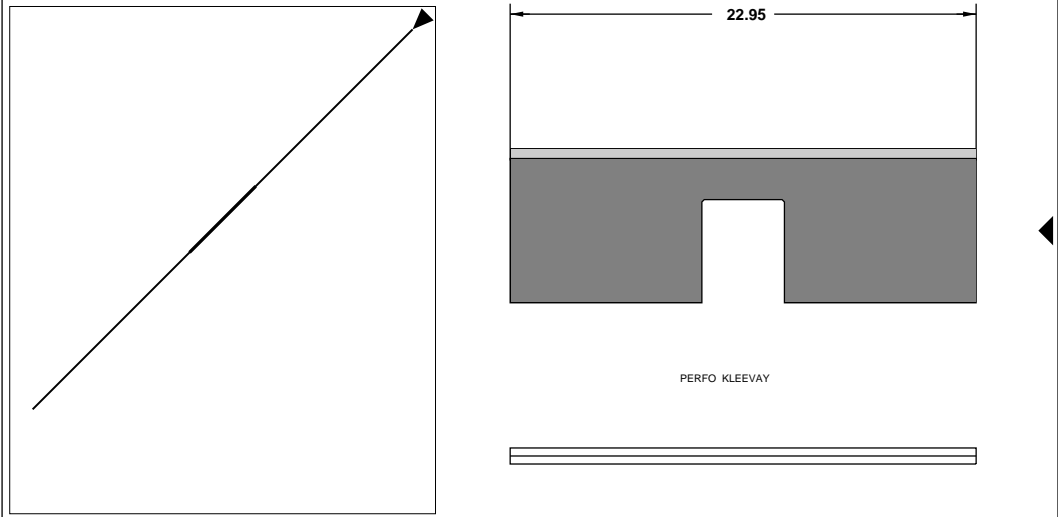

30	Line-No.		Date	27.02.2012	Order-No.		Amount	32	Supplier	
	Path	aserpack/filesW	Author	Yashin A	Height	23.80	Laserpack Fryazino			
	File	e> ECMA_B4150.d	Customer		Manufacturer	Boehler				
	Holz 10/15/18		Line type	PERFO	Material	UNIVERSAL-T30				
	Sonstiges		Pointage	2.00	Mat. Table	04	Die-Side			

Rule Processing System ACS 100 for ISO 9000

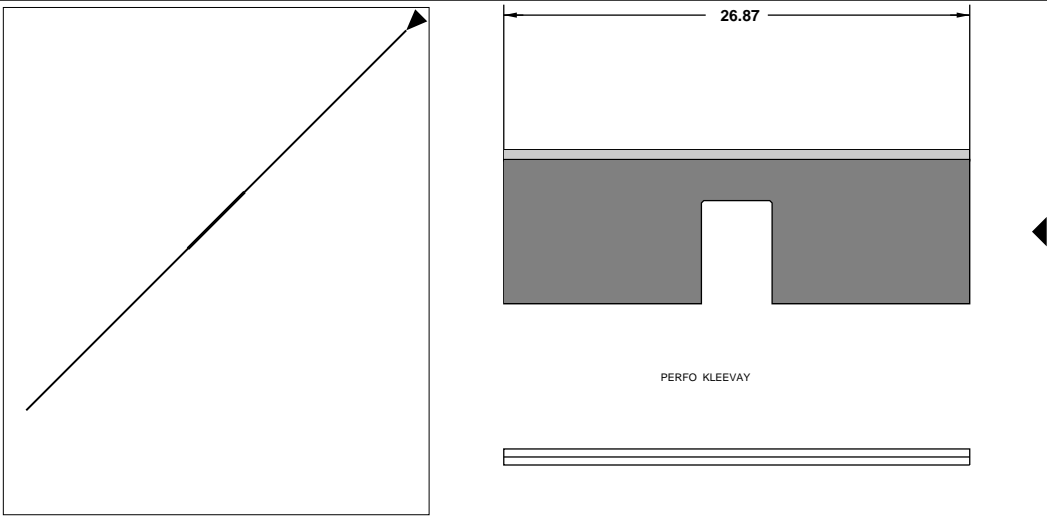

31	Line-No.		Date	27.02.2012	Order-No.		Amount	64	Supplier	
	Path	aserpack/filesW	Author	Yashin A	Height	23.80	Laserpack Fryazino			
	File	e> ECMA_B4150.d	Customer		Manufacturer	Boehler				
	Holz 10/15/18		Line type	PERFO	Material	UNIVERSAL-T30				
	Sonstiges		Pointage	2.00	Mat. Table	04	Die-Side			

Rule Processing System ACS 100 for ISO 9000

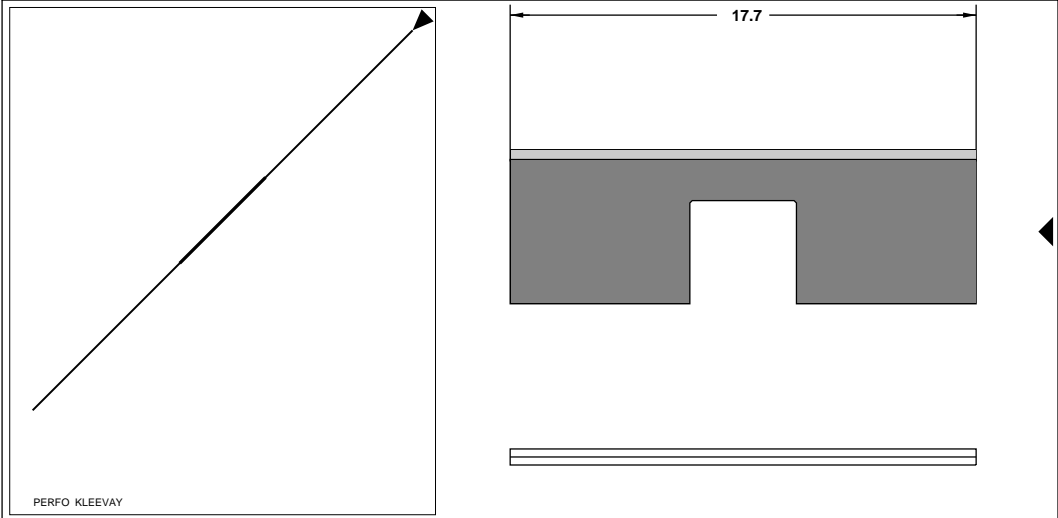

32	Line-No.		Date	27.02.2012	Order-No.		Amount	32	Supplier	
	Path	aserpack/filesW	Author	Yashin A	Height	23.80	Laserpack Fryazino			
	File	e> ECMA_B4150.d	Customer		Manufacturer	Boehler				
	Holz 10/15/18		Line type	PERFO	Material	UNIVERSAL-T30				
	Sonstiges		Pointage	2.00	Mat. Table	04	Die-Side			

Rule Processing System ACS 100 for ISO 9000

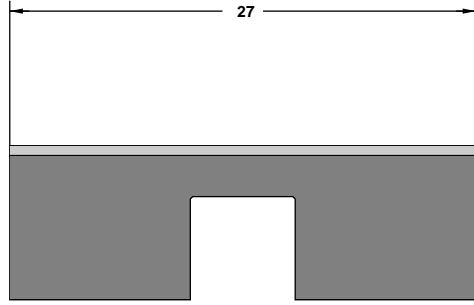
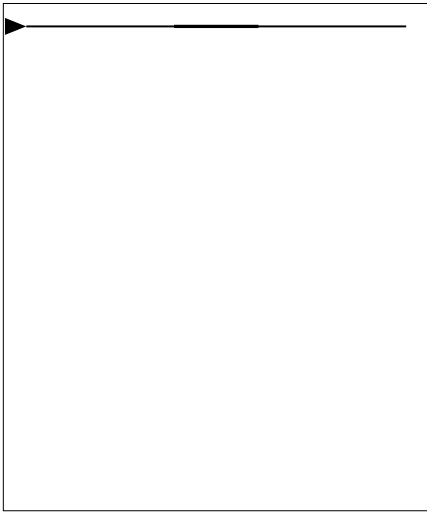

Line-No.	Date	27.02.2012	Order-No.		Amount	24	Supplier
33	Path	aserpack/filesW	Author	Yashin A	Height	23.20	Laserpack Fryazino
	File	e> ECMA_B4150.doc	Customer		Manufacturer	Boehler	
	Holz 10/15/18		Line type	Crease	Material	UNIVERSAL-T30	
	Sonstiges		Pointage	2.00	Mat. Table	04	
			Die-Side				

Rule Processing System ACS 100 for ISO 9000

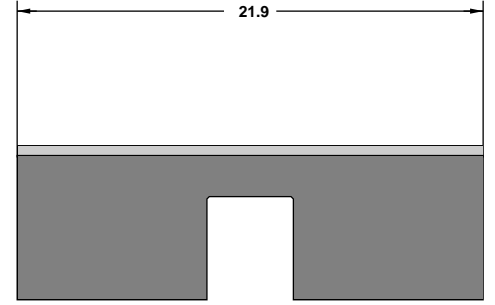
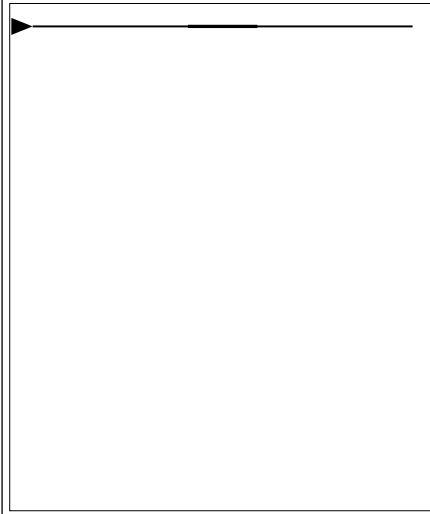

Line-No.	Date	27.02.2012	Order-No.		Amount	48	Supplier
34	Path	aserpack/filesW	Author	Yashin A	Height	23.20	Laserpack Fryazino
	File	e> ECMA_B4150.doc	Customer		Manufacturer	Boehler	
	Holz 10/15/18		Line type	Crease	Material	UNIVERSAL-T30	
	Sonstiges		Pointage	2.00	Mat. Table	04	
			Die-Side				

Rule Processing System ACS 100 for ISO 9000

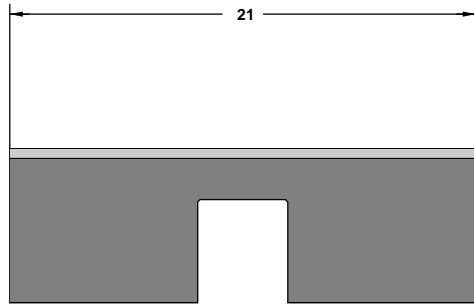
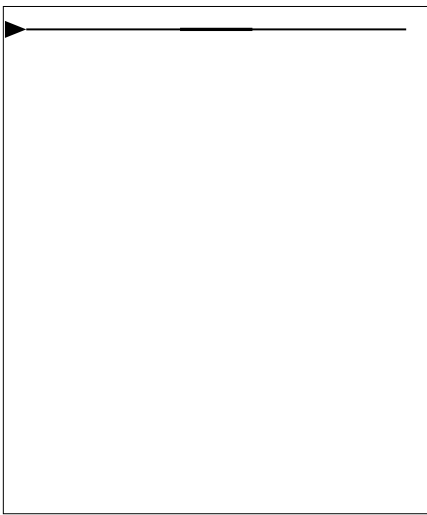

Line-No.	Date	27.02.2012	Order-No.		Amount	8	Supplier
35	Path	aserpack/filesW	Author	Yashin A	Height	23.20	Laserpack Fryazino
	File	e> ECMA_B4150.doc	Customer		Manufacturer	Boehler	
	Holz 10/15/18		Line type	Crease	Material	UNIVERSAL-T30	
	Sonstiges		Pointage	2.00	Mat. Table	04	
			Die-Side				

Rule Processing System ACS 100 for ISO 9000

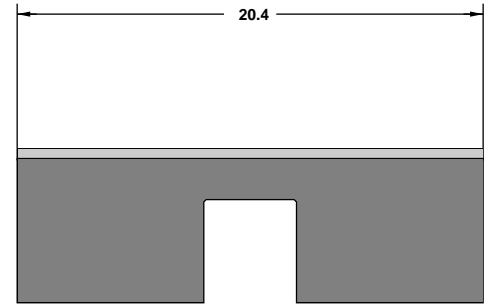

Line-No.	Date	27.02.2012	Order-No.		Amount	32	Supplier
36	Path	aserpack/filesW	Author	Yashin A	Height	23.20	Laserpack Fryazino
	File	e> ECMA_B4150.doc	Customer		Manufacturer	Boehler	
	Holz 10/15/18		Line type	Crease	Material	UNIVERSAL-T30	
	Sonstiges		Pointage	2.00	Mat. Table	04	
			Die-Side				

Rule Processing System ACS 100 for ISO 9000

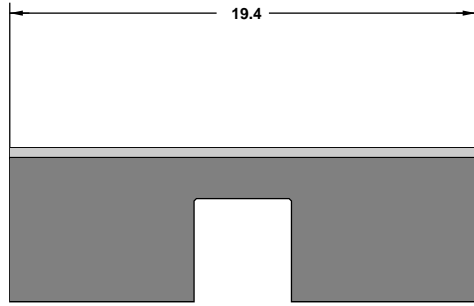
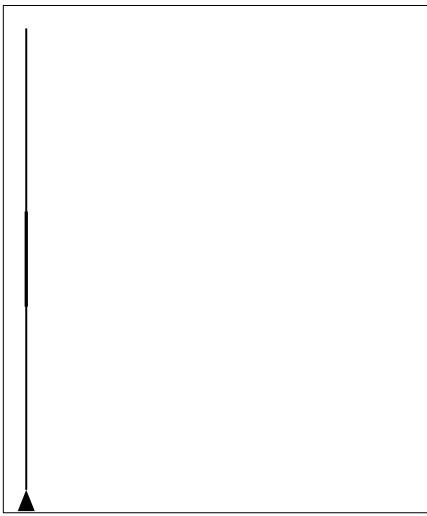

37	Line-No.		Date	27.02.2012	Order-No.		Amount	16	Supplier	
	Path	aserpack/filesW	Author	Yashin A	Height	23.20	Laserpack Fryazino			
	File	e> ECMA_B4150.doc	Customer		Manufacturer	Boehler				
	Holz 10/15/18		Line type	Crease	Material	UNIVERSAL-T30				
	Sonstiges		Pointage	2.00	Mat. Table	04	Die-Side			

Rule Processing System ACS 100 for ISO 9000

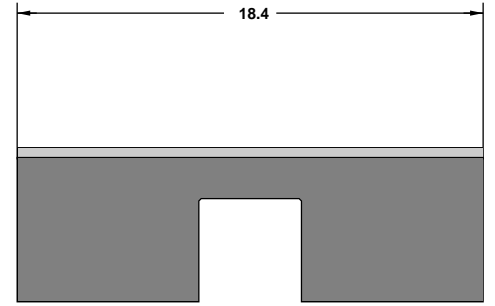

38	Line-No.		Date	27.02.2012	Order-No.		Amount	16	Supplier	
	Path	aserpack/filesW	Author	Yashin A	Height	23.20	Laserpack Fryazino			
	File	e> ECMA_B4150.doc	Customer		Manufacturer	Boehler				
	Holz 10/15/18		Line type	Crease	Material	UNIVERSAL-T30				
	Sonstiges		Pointage	2.00	Mat. Table	04	Die-Side			

Rule Processing System ACS 100 for ISO 9000

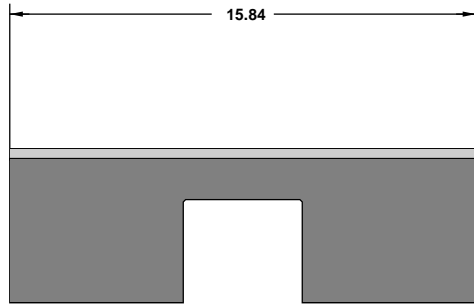
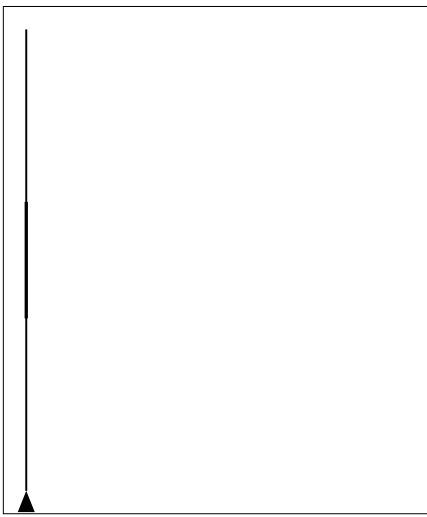

39	Line-No.		Date	27.02.2012	Order-No.		Amount	16	Supplier	
	Path	aserpack/filesW	Author	Yashin A	Height	23.20	Laserpack Fryazino			
	File	e> ECMA_B4150.doc	Customer		Manufacturer	Boehler				
	Holz 10/15/18		Line type	Crease	Material	UNIVERSAL-T30				
	Sonstiges		Pointage	2.00	Mat. Table	04	Die-Side			

Rule Processing System ACS 100 for ISO 9000

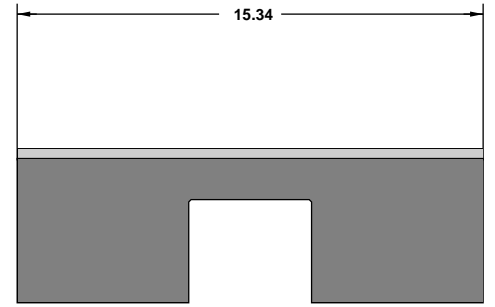

40	Line-No.		Date	27.02.2012	Order-No.		Amount	16	Supplier	
	Path	aserpack/filesW	Author	Yashin A	Height	23.20	Laserpack Fryazino			
	File	e> ECMA_B4150.doc	Customer		Manufacturer	Boehler				
	Holz 10/15/18		Line type	Crease	Material	UNIVERSAL-T30				
	Sonstiges		Pointage	2.00	Mat. Table	04	Die-Side			

Rule Processing System ACS 100 for ISO 9000

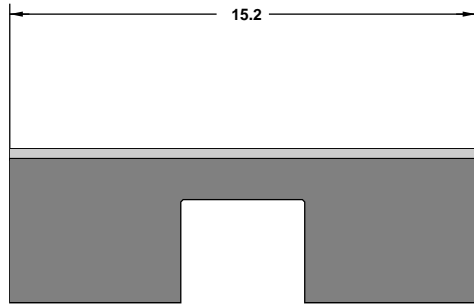
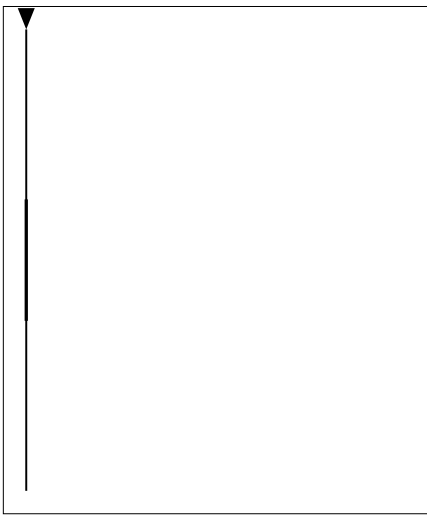

41	Line-No.		Date	27.02.2012	Order-No.		Amount	32	Supplier	
	Path	aserpack/filesW	Author	Yashin A	Height	23.20	Laserpack Fryazino			
	File	e> ECMA_B4150.doc	Customer		Manufacturer	Boehler				
	Holz 10/15/18		Line type	Crease	Material	UNIVERSAL-T30				
	Sonstiges		Pointage	2.00	Mat. Table	04	Die-Side			

Rule Processing System ACS 100 for ISO 9000

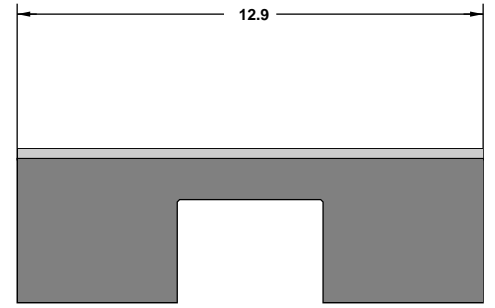
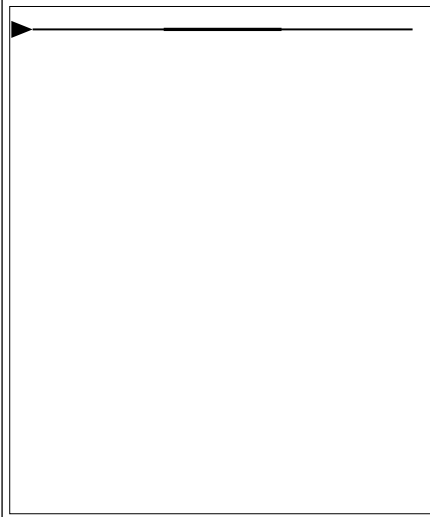

42	Line-No.		Date	27.02.2012	Order-No.		Amount	16	Supplier	
	Path	aserpack/filesW	Author	Yashin A	Height	23.20	Laserpack Fryazino			
	File	e> ECMA_B4150.doc	Customer		Manufacturer	Boehler				
	Holz 10/15/18		Line type	Crease	Material	UNIVERSAL-T30				
	Sonstiges		Pointage	2.00	Mat. Table	04	Die-Side			

Rule Processing System ACS 100 for ISO 9000

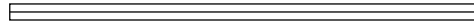
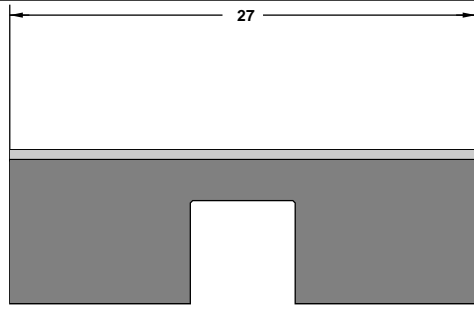
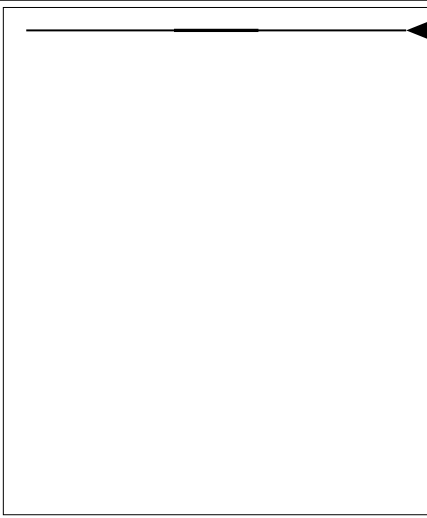

RitzL !!!

43	Line-No.		Date	27.02.2012	Order-No.		Amount	64	Supplier	
	Path	aserpack/filesW	Author	Yashin A	Height	23.80	Laserpack Fryazino			
	File	e> ECMA_B4150.doc	Customer		Manufacturer	Boehler				
	Holz 10/15/18		Line type	Score	Material	UNIVERSAL-T30				
	Sonstiges		Pointage	2.00	Mat. Table	04	Die-Side			

Rule Processing System ACS 100 for ISO 9000

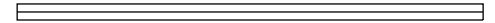
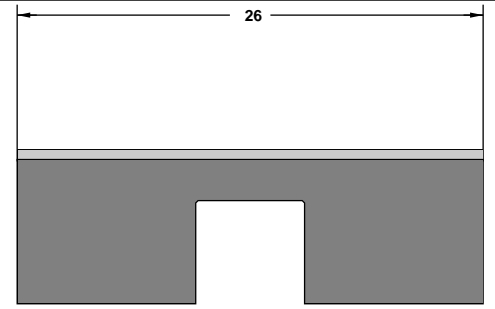

44	Line-No.		Date	27.02.2012	Order-No.		Amount	32	Supplier	
	Path	aserpack/filesW	Author	Yashin A	Height	23.80	Laserpack Fryazino			
	File	e> ECMA_B4150.doc	Customer		Manufacturer	Boehler				
	Holz 10/15/18		Line type	Score	Material	UNIVERSAL-T30				
	Sonstiges		Pointage	2.00	Mat. Table	04	Die-Side			

Rule Processing System ACS 100 for ISO 9000

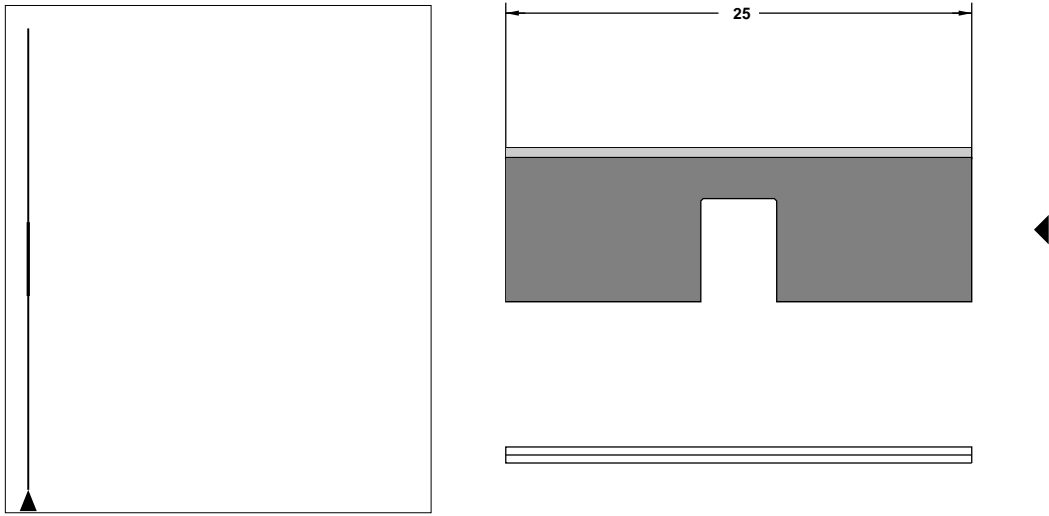

Line-No.	Date	27.02.2012	Order-No.		Amount	32	Supplier		
45	Path	aserpack/filesW	Author	Yashin A	Height	23.80	Laserpack Fryazino		
	File	e> ECMA_B4150.dds	Customer		Manufacturer	Boehler			
	Holz 10/15/18		Line type	Score	Material	UNIVERSAL-T30			
	Sonstiges		Pointage	2.00	Mat. Table	04		Die-Side	

Rule Processing System ACS 100 for ISO 9000



complete list

Date	File	Order-No.	Author	Customer	Up
27.02.2012	e> ECMA_B4150.dds		Yashin A		1

No.	Line type	Height	Point.	Amount	Bridges		BEMDMARK		KBends		Broaching		Length	Sum	Total	Manufacturer	Mat. Table
					Sing.	Sum	Sing.	Sum	Sing.	Sum	Sing.	Sum					
1	Cut	23.80	2.00	1	8	8	0	0	0	0	0	0	530.00	530.00		Boehler	04
2	Cut	23.80	2.00	1	7	7	0	0	0	0	0	0	469.50	469.50		Boehler	04
3	Cut	23.80	2.00	6	3	18	0	0	0	0	0	0	197.50	1185.00		Boehler	04
4	Cut	23.80	2.00	2	3	6	0	0	0	0	0	0	177.50	355.00		Boehler	04
5	Cut	23.80	2.00	6	2	12	0	0	0	0	0	0	133.50	801.00		Boehler	04
6	Cut	23.80	2.00	8	4	32	6	48	4	32	1	8	137.46	1099.68		Boehler	04
7	Cut	23.80	2.00	8	4	32	6	48	4	32	1	8	137.46	1099.68		Boehler	04
8	Cut	23.80	2.00	8	2	16	2	16	2	16	1	8	61.71	493.68		Boehler	04
9	Cut	23.80	2.00	8	2	16	2	16	2	16	1	8	61.71	493.68		Boehler	04
10	Cut	23.80	2.00	12	2	24	0	0	0	0	2	24	51.48	617.76		Boehler	04
11	Cut	23.80	2.00	8	0	0	2	16	2	16	1	8	23.96	191.68		Boehler	04
12	Cut	23.80	2.00	16	1	16	0	0	0	0	0	0	29.73	475.68		Boehler	04
13	Cut	23.80	2.00	4	1	4	3	12	3	12	2	8	57.00	228.00		Boehler	04
14	Cut	23.80	2.00	8	9	72	4	32	4	32	4	32	282.79	2262.32		Boehler	04
15	Cut	23.80	2.00	4	0	0	2	8	2	8	1	4	23.96	95.84	10398.50	Boehler	04
16	PERFO	23.80	2.00	4	4	16	4	16	4	16	4	16	161.88	647.52		Boehler	04
17	PERFO	23.80	2.00	8	3	24	3	24	3	24	3	24	115.38	923.04		Boehler	04
18	PERFO	23.80	2.00	4	3	12	3	12	3	12	3	12	115.38	461.52	2032.08	Boehler	04
19	Cut	23.80	2.00	4	5	20	4	16	2	8	0	0	147.18	588.72		Boehler	04
20	Cut	23.80	2.00	4	1	4	1	4	0	0	0	0	25.36	101.44		Boehler	04

Rule Processing System ACS 100 for ISO 9000



complete list

Date	File	Order-No.	Author	Customer	Up
27.02.2012	e> ECMA_B4150.dds		Yashin A		1

No.	Line type	Height	Point.	Amount	Bridges		BEMDMARK		KBends		Broaching		Length	Sum	Total	Manufacturer	Mat. Table
					Sing.	Sum	Sing.	Sum	Sing.	Sum	Sing.	Sum					
21	Cut	23.80	2.00	4	1	4	1	4	0	0	0	0	25.36	101.44		Boehler	04
22	Cut	23.80	2.00	4	4	16	0	0	0	0	0	0	190.72	762.88		Boehler	04
23	Cut	23.80	2.00	2	4	8	0	0	0	0	0	0	214.34	428.68		Boehler	04
24	Cut	23.80	2.00	3	3	9	0	0	0	0	0	0	117.92	353.76		Boehler	04
25	Cut	23.80	2.00	1	2	2	0	0	0	0	0	0	69.67	69.67		Boehler	04
26	Cut	23.80	2.00	2	1	2	0	0	0	0	0	0	20.17	40.34		Boehler	04
27	Cut	23.80	2.00	3	2	6	0	0	0	0	0	0	79.42	238.26		Boehler	04
28	Cut	23.80	2.00	1	1	1	1	1	1	1	0	0	31.42	31.42		Boehler	04
29	Cut	23.80	2.00	1	1	1	1	1	1	1	0	0	31.42	31.42	2748.03	Boehler	04
30	PERFO	23.80	2.00	32	1	32	0	0	0	0	0	0	22.95	734.40		Boehler	04
31	PERFO	23.80	2.00	64	1	64	0	0	0	0	0	0	26.87	1719.68		Boehler	04
32	PERFO	23.80	2.00	32	1	32	0	0	0	0	0	0	17.70	566.40	3020.48	Boehler	04
33	Crease	23.20	2.00	24	1	24	0	0	0	0	0	0	27.00	648.00		Boehler	04
34	Crease	23.20	2.00	48	1	48	0	0	0	0	0	0	21.90	1051.20		Boehler	04
35	Crease	23.20	2.00	8	1	8	0	0	0	0	0	0	21.00	168.00		Boehler	04
36	Crease	23.20	2.00	32	1	32	0	0	0	0	0	0	20.40	652.80		Boehler	04
37	Crease	23.20	2.00	16	1	16	0	0	0	0	0	0	19.40	310.40		Boehler	04
38	Crease	23.20	2.00	16	1	16	0	0	0	0	0	0	18.40	294.40		Boehler	04
39	Crease	23.20	2.00	16	1	16	0	0	0	0	0	0	15.84	253.44		Boehler	04
40	Crease	23.20	2.00	16	1	16	0	0	0	0	0	0	15.34	245.44		Boehler	04

Rule Processing System ACS 100 for ISO 9000



complete list

Date	File	Order-No.	Author	Customer	Up
27.02.2012	e> ECMA_B4150.dds		Yashin A		1

No.	Line type	Height	Point.	Amount	Bridges		BEMDMARK		KBends		Broaching		Length	Sum	Total	Manufacturer	Mat. Table
					Sing.	Sum	Sing.	Sum	Sing.	Sum	Sing.	Sum					
41	Crease	23.20	2.00	32	1	32	0	0	0	0	0	0	15.20	486.40		Boehler	04
42	Crease	23.20	2.00	16	1	16	0	0	0	0	0	0	12.90	206.40	4316.48	Boehler	04
43	Score	23.80	2.00	64	1	64	0	0	0	0	0	0	27.00	1728.00		Boehler	04
44	Score	23.80	2.00	32	1	32	0	0	0	0	0	0	26.00	832.00		Boehler	04
45	Score	23.80	2.00	32	1	32	0	0	0	0	0	0	25.00	800.00	3360.00	Boehler	04
				625		868		274		226		160			25875.57		